



Multifeeder Technology

IP FEEDER PARTS BOOK

P/N 39008-00

4821 White Bear Parkway
White Bear Lake, MN 55110
651-407-3100
651-407-3199-Fax

December 18, 2003

This Parts Book is Copyright Multifeeder Technology, Inc. ©2002. All rights reserved.
This Parts Book is not to be duplicated without the express written consent of Multifeeder Technology, Inc.

TABLE OF CONTENTS

INTRODUCTION.....	4
1 SAFETY	8
2 TERMS AND TERMINOLOGY	10
3 INSTALLATION AND SETUP	12
4 IP FEEDER MAIN PARTS.....	13
5 IP FEEDER DISCHARGE.....	19
6 IP FEEDER DRIVE SECTION	22
7 IP FEEDER LEFT SIDE HOUSING.....	24
8 IP FEEDER RIGHT SIDE HOUSING.....	25
9 IP FEEDER SENSORS AND SENSOR BRACKETS	28
10 IP FEEDER PRESSURE ROLLER ASSEMBLIES.....	31
11 IP FEEDER STATIC BAR ASSEMBLIES	32
12 IP FEEDER INTERFACING EQUIPMENT	33
13 IP FEEDER SPARE PART KITS.....	35

Introduction

Congratulations on the purchase of your new MFT Friction Feeder from Multifeeder Technology, Inc. Since 1996, Multifeeder Friction Feeders have set “The *NEW* Standard in High Performance, High Speed Friction Feeding”. This document is designed to provide you with the information necessary for basic set up and operation of the feeder. The information is divided among 7 sections summarized below:

Section 1. *Safety* – The safety section outlines the general safety precautions you should use when operating the feeder.

Section 2. *Terms and Terminology* – The terms and terminology section describes the main components of your MFT Friction Feeder and introduces you to terminology used later in the manual.

Section 3. *Installation and Setup* – This section provides step-by-step instructions on how to install and set up the feeder. Information on how to attach optional accessories is also included.

Section 4. *Membrane Keypad Controls* – The controls section describes in detail each of the key commands on the membrane keypad and those under the Menu function.

Section 5. *Electronic Schematics* – The electronic schematics section provides you with diagrams and explanations of the wiring in the feeder.

Section 6. *Troubleshooting* – This section provides you with ideas on how to troubleshoot your feeding problems if they should occur.

Section 7. *Maintenance* – The maintenance section describes the necessary operations that must be performed to ensure optimal feeder performance.

This machine is designed for use by operators with basic knowledge of machine functions and with basic math ability. In order for the machine to operate as intended, it must be installed properly and basic maintenance must be performed at regular intervals. Modifications of any kind to the system may result in less than optimal feeder performance, voiding of the warranty, unsafe operation, and thus is not recommended.

Technical phone support is available by calling (651) 407-3100 Monday – Friday, 8 am to 5 PM (CST). Please be near your MFT Friction Feeder when you call.

**TERMS AND CONDITIONS OF SALE OR LEASE
MULTIFEEDER TECHNOLOGY, INC. (MFT)**

Acceptance (Offer and Agreement). These terms and conditions constitute the entire and exclusive agreement between the parties. No other modification of these conditions of sale or lease shall be effective unless made in writing and signed by both parties.

Assent to Terms and Conditions. Buyer agrees it has full knowledge of the conditions printed herein and that the same are part of the agreement between Buyer and Seller and shall be binding. Irrespective of the fact that one or more terms may be left open in this Agreement the Parties do intend to make a contract.

Prior Agreements. It is understood that there are no conditions or agreements outside of this written proposal and that all prior conversations, agreements or representation with reference to the subject matter contained herein are hereby superseded.

Price, Price Adjustment & Additional Charges. Prices quoted are based on material and labor cost as of the date of the estimate, and is subject to increase or decrease in accordance with any change of labor or material cost that may transpire before acceptance. Quoted prices do not constitute acceptance of the job. Only after review of final specifications and all pertinent information at the time of the order, will the price be considered accepted by the Seller. The proposal is only for work according to the original specification upon which the proposal is based. Additional work done or time consumed by reason of Buyer's alterations or changes made in work or material and other delays caused by Buyer, will be charged for at the current rate. The quotation is subject to acceptance within 30 days. It is not subject to partial acceptance except by written mutual agreement. A quotation not accepted within 30 days is subject to review. Prices are in U.S. Dollars and are exclusive of any federal, state or local excise, sales, use or other applicable tax and are F.O.B. Multifeeder Technology Inc.'s place of business. Transfer of title is not deemed to occur until payment in full has been received by MultifeederTechnology, Inc.

Credit. The Seller shall have the right to review any and all necessary credit reports and information to assess whether or not credit may be extended to Buyer. The Seller shall have the right to, if necessary, to place liens on Buyer's property if payment is not received after written warnings have been made and reasonable time has been allowed for corrective action.

Payment Terms. Payment terms are specified in the proposal or else are 55% prepaid with the placement of the purchase order, 35% received prior to shipment, and 10% net 30 days after delivery, if credit has been approved. Otherwise terms are cash or irrevocable letter of credit. Seller reserves the right to charge interest on all invoices not paid at maturity.

Shipment. Shipment or delivery dates are the best estimate of when product will be shipped. Costs of transportation and risk of loss during shipment will be borne by the Buyer. MFT shall not be liable for any damages caused by delays or failures to ship beyond its reasonable control, including without limitation, acts of God, acts of insurrection, delays by the shipper, strikes, inability to obtain materials, acts of any governmental agency or the like. In any event the date of delivery shall be extended for a period of time equal to the time lost by reason of delay, and the Buyer's sole and exclusive remedy shall be its right to terminate that portion of its order subject to the delay, unless caused by the shipper, and its proportionate obligation for the purchase price thereof. Unless specifically specified to the contrary, partial shipments shall be permitted.

Price Adjustments. Prices are based on the specifications available for review at the time of the quotation. Should the specifications be changed after the quotation has been made prices will be subject to revision.

Confidentiality. The parties acknowledge that MFT's technology is to be maintained confidential, and Buyer agrees not to disclose or utilize any such technology, which it learns in connection herewith, except for disclosure of information that has otherwise become knowledgeable to the public. The purchase of MFT products in no manner implies or authorizes any form of technology license to use any portion of MFT's technology except for the use of MFT products for their intended purpose. Buyer and all of its assignees and/or transferees of any part or all of the products sold hereunder including all associated proprietary, patentable, and intellectual property rights herewith agree to all the terms and conditions of sale herein, and Buyer agrees to indemnify, defend and hold harmless MFT for any claim or loss or damage suffered by MFT as a result of any assignee or transferee failing to abide by these terms and conditions.

Cancellation. Cancellation of orders placed and accepted can be made only with our written consent, and upon terms which will indemnify MFT against loss, including but not limited to all costs and prospective profits, hereby set as a minimum 35% cancellation charge of the purchase price of the equipment.

LIMITED WARRANTY AND LIMITATION OF LIABILITY. MULTIFEEDER TECHNOLOGY, INCORPORATED (MFT) warrants to the purchaser, for a period of one year from the date of shipment or for 2000 operating hours, whichever occurs first, each system shall be free of defects in materials and workmanship such that each system properly used shall perform to specifications supplied within the applicable manual. MFT shall repair all systems or accessories found to be defective in accordance with this warranty, free of charge, for which MFT has been notified by the purchaser by serial number that there is a defect, provided said notification occurs within the applicable warranty period, except that wear items such as belts and stripper wheels are excluded. THE EXPRESS WARRANTY SET FORTH HEREIN SHALL BE THE SOLE AND EXCLUSIVE REMEDY BY THE PURCHASER

This document, submitted in confidence, contains proprietary and confidential information which shall not be reproduced or transferred to other documents or disclosed to others or used for manufacturing or any other purpose, including advertising without prior written permission from a Multifeeder Technology, Inc. representative.

HEREUNDER FOR ANY SYSTEMS OR ACCESSORIES DELIVERED TO THE PURCHASER WHICH ARE FOUND TO BE DEFECTIVE IN ANY MANNER WHETHER SUCH REMEDIES BE IN CONTRACT, TORT OR BY LAW. NO OTHER WARRANTIES OF ANY KIND, WHETHER STATUTORY, WRITTEN, ORAL, OR IMPLIED INCLUDING WARRANTIES OF FITNESS FOR A PARTICULAR PURPOSE OR MERCHANTABILITY SHALL APPLY. MFT does not represent or warrant that equipment sold by it complies with OSHA or any like state or local law or regulation, and the cost of modification and responsibility for compliance is imposed on the buyer.

THE TOTAL CUMULATIVE LIABILITY OF MFT TO BUYER FOR ANY CLAIM OF ANY KIND WHETHER BASED UPON CONTRACT, TORT (INCLUDING NEGLIGENCE), STRICT LIABILITY, OR OTHERWISE, FOR ANY LOSS OR DAMAGE WHATSOEVER ARISING OUT OF, CONNECTED WITH OR RESULTING FROM THE SALE OR SERVICING OF THE SYSTEMS HEREIN SHALL NOT EXCEED THE PURCHASE PRICE OF THE AFFECTED SYSTEM OR COST OF SERVICES BY MFT ON THE SAME, WHICHEVER IS APPROPRIATE. PROVIDED FURTHER THAT BUYER AGREES TO INDEMNIFY, DEFEND AND HOLD HARMLESS MFT FROM ALL CLAIMS ARISING IN WHOLE OR IN PART ON ACCOUNT OF IMPROPER USE, ABUSE, MISUSE OR USE NOT IN ACCORDANCE WITH MFT'S RECOMMENDATIONS IN THE INSTRUCTION MANUAL SUPPLIED WITH THESE PRODUCTS. IN NO EVENT SHALL MFT BE RESPONSIBLE FOR ANY LOSS OF USE, LOSS OF PRODUCT, LOSS OF REVENUE, LOSS OF PROFIT, COST OF CAPITAL OR FOR ANY OTHER INDIRECT, CONSEQUENTIAL OR SPECIAL DAMAGES OF ANY NATURE HOWSOEVER ARISING.

This warranty excludes cost of delivery to and from MFT. All repaired units shall be received by the purchaser at MFT's place of business. For any system or accessory sent to MFT for warranty repair, which is found to be within specification, the purchaser agrees to pay a service fee of \$500.00.

These systems and accessories are sensitive and must be repaired by knowledgeable and specially trained personnel only. Accordingly, any sign or evidence of opening the system, field service by non-MFT personnel, or non-trained personnel, tampering, or any kind of misuse including use of belts, stripper wheels or other parts not sold by MFT, or abuse of the system or accessories, shall void the warranty in its entirety. All non-warranty work shall be done according to MFT standard rates and charges in effect at the time of delivery to MFT.

OSHA Laws. The Williams-Steiger Occupational Safety and Health Act of 1970 (OSHA) and like state and local laws and all regulations issued under such laws are designed to assure a safe place to work and apply primarily to the employer, not the equipment manufacturer. Seller will work with buyer to find technically feasible answers to possible compliance problems; however, because compliance is significantly affected by many factors over which seller has little control (such as installation, plant layout, building acoustics, material processed, processing procedures and supervision and training of employees), Seller does not represent or warrant that equipment sold by it complies with OSHA or any state or local law or regulation, and the cost of modifications and responsibility for compliance are the Buyer's responsibility.

Patents. Multifeeder Technology, Inc. warrants that it has sought legal counsel and utilized its best efforts to ensure that it does not infringe on anyone's patented technology and will at its option if found to infringe a) redesign to avoid infringement or b) seek a license to allow the current technology to be utilized or c) allow the customer to return the product for a full refund.

GOVERNING LAW AND VENUE. This agreement has been made, executed and delivered from Minnesota, in which State the offices of Multifeeder Technology, Inc. (MFT) are located. Accordingly, the parties hereto invoke the laws of Minnesota regarding the protection of their rights and the enforcement of their obligations hereunder and they agree that this Agreement is in all respects including, but not limited to, all matters of interpretation, validity, performance and the consequences of breach of this agreement, to be exclusively construed, governed and enforced in accordance with the internal laws (excluding all conflict of law rules) of Minnesota and in any applicable Federal laws of the United States of America, as from time to time amended and in effect. The parties agree that the United Nations Convention on contracts for the international sales of goods shall not apply in any respect to this Agreement or the parties hereto. By accepting MFT's proposal, the Purchaser consents and submits to the jurisdiction and venue over any action, suit or other legal proceedings may arise out of or in connection with this Agreement, by the appropriate District Court in Minnesota. The Purchaser hereby waives any objections to jurisdiction or venue in any proceedings before any such court in Minnesota. THIS SALE OR LEASE AND BUYER'S RIGHT TO USE ALL OF MFT'S PRODUCTS, MACHINES AND MATERIALS IS CONDITIONED UPON ACCEPTANCE OF THE ENCLOSED TERMS AND CONDITIONS. The terms and conditions set forth herein shall supersede all preprinted terms and condition on both Buyer's and MFT's usual purchase, sale, or lease documents and no inconsistent nor additional commercial terms or conditions, including price shall be applicable unless specifically agreed to in writing by both parties. The terms of this contract shall be binding upon the Buyer and its successors and assigns. MFT shall not be held responsible for errors of misunderstanding which may occur relevant to the contents of this document resulting from the omissions or translations to another language. MFT reserves the right to correct any errors.

03/06

SUBJECT TO CHANGE WITHOUT NOTICE.

This document, submitted in confidence, contains proprietary and confidential information which shall not be reproduced or transferred to other documents or disclosed to others or used for manufacturing or any other purpose, including advertising without prior written permission from a Multifeeder Technology, Inc. representative.

1 Safety

All equipment from Multifeeder Technology is designed with safety in mind. However, in order to ensure your safety and the safety of others around you, common sense must always be used when operating this machine. Please read this section of the manual carefully before installing or operating your MFT Friction Feeder.

Table 1.1 Personal Safety Warnings

Personal Safety Warnings

These warnings are given to help you avoid personal injury

- Do not install or operate your MFT Friction Feeder without first reading this manual completely.
- This machine operates on 120 or 220 VAC. Contact with this voltage can lead to serious injury, or death.
- Always press the FEEDER OFF key and disconnect the power cord before removing any housing covers for service or inspection.
- Always press the FEEDER OFF key and disconnect the main power cord before working with any of the feeder's electrical components.
- Always press the FEEDER OFF key and disconnect the power cord before reaching into the feeding area of the machine to perform maintenance tasks.
- Make sure loose jewelry, clothing, long hair, neckties, etc. are properly secured before you operate the feeder.
- Do not operate the feeder, make mechanical adjustments, or perform maintenance tasks while under the influence of drugs or alcohol.
- Keep hands away from moving parts at all times while the feeder is operating.
- Always isolate the feeder and press the FEEDER OFF key before reaching into the feeding area of the machine to perform setup tasks, make mechanical adjustments, or clear jams.
- Be aware of the location of the STOP MOTOR key on the membrane keypad. In case of an emergency, this key may be pressed at any time to instantly stop the motor. The machine may also be powered off or unplugged in an emergency.
- Use proper lifting techniques when moving this machine.
- Be aware of static electricity build up on products being fed.

Table 1.2 Machine Precautions

Machine Precautions

These precautions are given to avoid damage to the MFT Friction Feeder

- ☒ A circuit analyzer and surge protector have been provided to you by MFT. Before connecting the surge protector or power cord, verify the integrity of your electrical source by plugging in the circuit analyzer. If the analyzer indicates the outlet is wired correctly, remove the analyzer and plug in the surge protector. Plug the three-prong standard power cord into the J5-Power Entry connector located on the back of the electrical feeder housing, plug the other end of the power cord into the surge protector and turn on the feeder. Please note that the power up sequence takes 30-60 seconds.
- ☒ Do not install or operate your MFT Friction Feeder without first reading this manual completely.
- ☒ Always press the FEEDER OFF key and disconnect the power cord before removing any housing covers for service or inspection.
- ☒ When moving the machine, do not lift from the discharge table or shafts.
- ☒ Make sure the feeder is securely mounted before enabling the motor.
- ☒ Use only fuses of the correct type, voltage, and current ratings. (5 x 20mm, 10A, 250V)
- ☒ To turn off the machine, always press the red OFF button on the membrane keypad before turning off the machine.
- ☒ Do not stack items on the machine when it is not in use.
- ☒ Always press the FEEDER OFF key before performing any setup tasks or making mechanical adjustments.
- ☒ Perform regular maintenance as prescribed in Chapter 7. Failure to do so may result in damage to the machine.
- ☒ Maintenance tasks should be performed according to the methods described in this manual by properly trained personnel.
- ☒ Mechanical adjustments should be performed according to the methods described in this manual by properly trained personnel.
- ☒ This machine should be operated within the following environmental range: Temperature 10-35°C (50-95°F), the recommended relative humidity range is 30% to 60% with 80% maximum.
- ☒ This machine should be operated in a well-lit area.
- ☒ This machine should not be operated around loose cords.
- ☒ This machine should not be operated around loose tools or objects such as screwdrivers, pliers, paper clips, or anything that may accidentally fall into the feeder.

2 Terms and Terminology

The MFT IP Family of Friction Feeders are ruggedly built machines designed to feed and count flat materials at high speeds without any damage to the product. The feeders consist of two feeder housing enclosures, one on each side of the feeder machine as shown in Figures 2.1 and 2.2. With the exception of the main drive motor, all electronic parts are mounted inside the electrical housing (operator side). The main drive motor is connected to the drive mechanism inside the mechanical housing (non-operator side). The two feeder housings form the base of a rigid frame supported by housing frame brackets in the rear, and a magazine support assembly in the front.

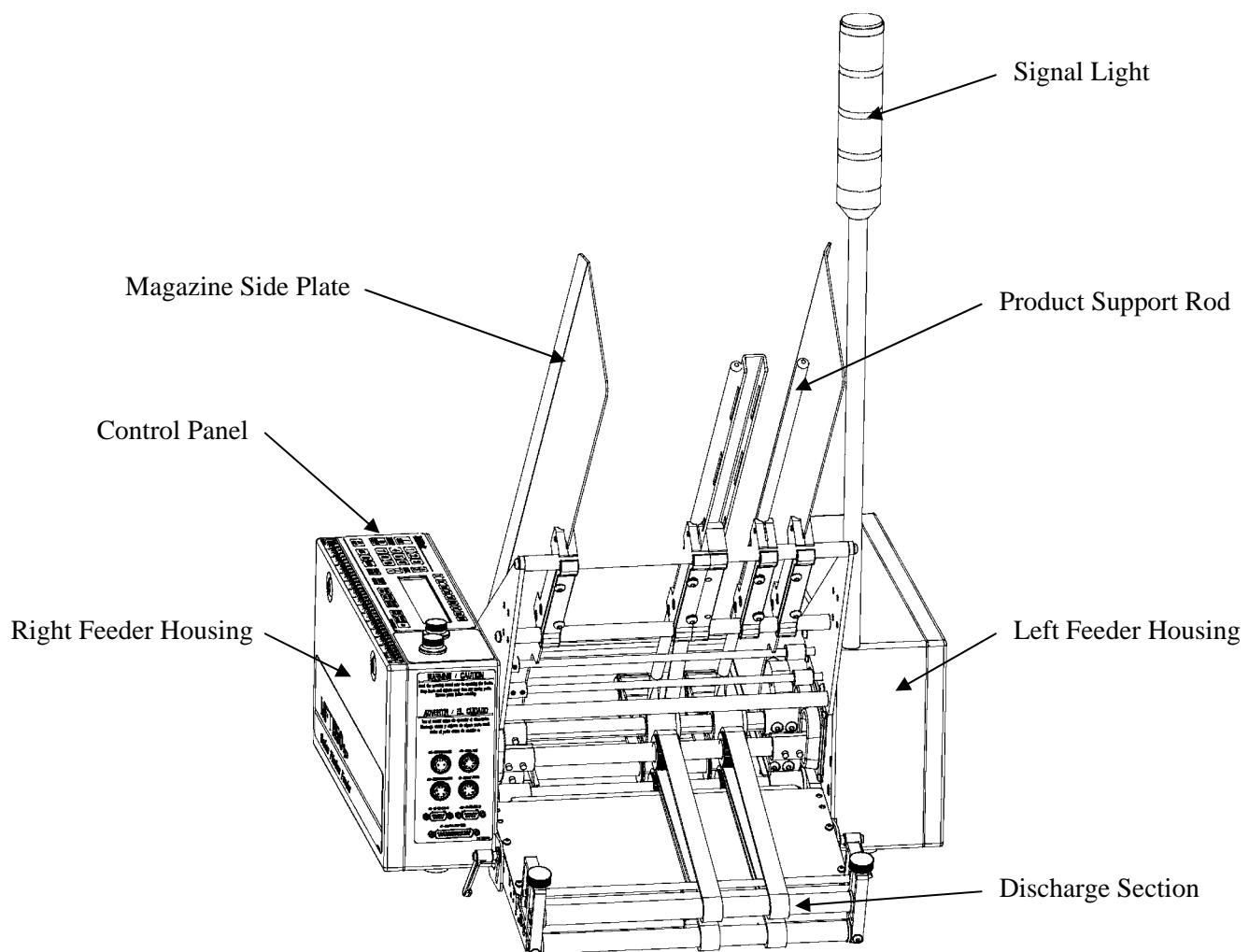

Figure 2.1 - MFT IP Friction Feeder Front View Descriptions

The product stack is held in position by the magazine side plates, the product support rods, and the product support curve assembly in the rear, see Figure 2.1 and Figure 2.2. Depending upon the feeder model and the product being fed, the number of product support curve assemblies, feed belts, stripper wheels, and discharge belts may vary. To accommodate different product thicknesses, the stripper wheels may be raised or lowered by using the thickness adjuster knob.

A discharge section is mounted in the front of the feeder to properly hold the products from the bottom and top as they are accelerated from the feed section onto a target. This discharge section can be adjusted to different angles depending on the application.

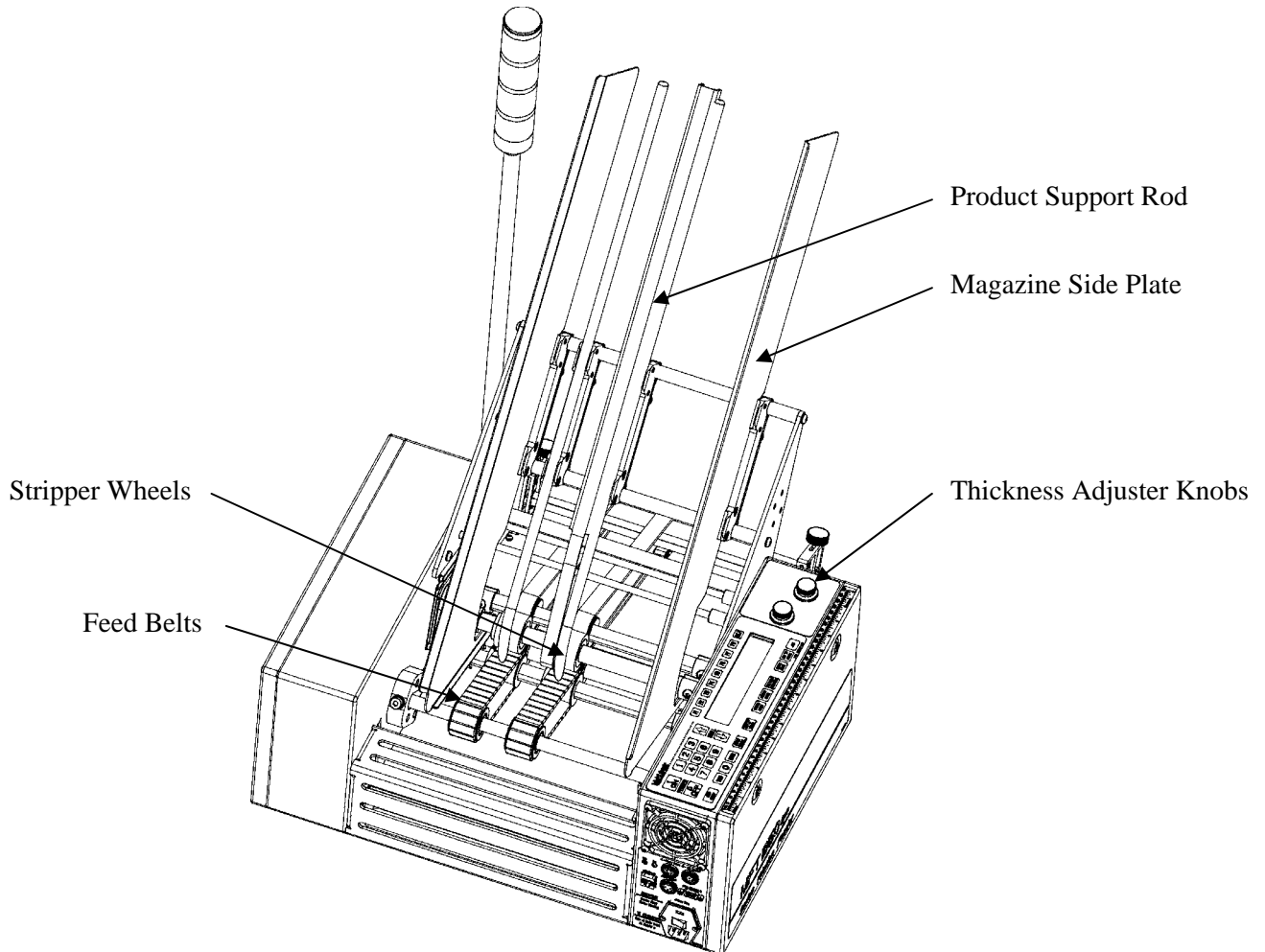

Figure 2.2 - MFT IP Friction Feeder Rear View Descriptions

The control panel features a custom membrane keypad, as shown Figure 2.2. The control panel is mounted on top of the electrical housing to accommodate easy access and set up. A three-color signal light is also mounted on top of the electrical housing to provide a feeding status that can be seen from a distance.

3 Installation and Setup

NOTE! Before installing the feeder, check your packing slip to make sure your shipment contains all items as specified. If your shipment is missing any items, please contact MFT. If items have been damaged during shipment, contact the shipper or trucking company immediately.

1. Using appropriate lifting means, carefully remove the feeder assembly from its box and place it in its correct operating position and direction.
2. Use a Multifeeder Technology Stand-On-Rollers and compatible mounting hardware or mounting provided by the user to securely mount the friction feeder.
3. Install the Product Support Curve Assembly(s). Product support curve assemblies should be placed on the top of the slotted housing frame bracket for small products and on the back of the housing frame bracket for large products.
4. Install the Product Support Rod Assemblies. Each product support rod assembly should be mounted as shown in Figures 2.1 and 2.2. Position the product support rod assemblies so that the curved sharpened tip faces inward and is aligned with the center line of the feed belt and that it does not touch either the stripper wheel or feed belt. If two or more product support curves are used, they should be positioned at identical heights and locations with respect to the stripper wheels and feed belts.
5. Install the Magazine Side Plate Assemblies. Place one magazine side plate assembly on the outside of the far right feed belt assembly and one on the outside of the far left feed belt assembly. **NOTE!** The magazine plate lips should face in towards the feed belts.
6. If ordered, install the Low Product Sensor. Plug the Low Product Sensor into the J3-Low Product connector located on the back of the electrical feeder housing.
7. If ordered, install the Photo-Optic / Proximity Start Sensor. Plug the start sensor into the J1-start status connector located on the back of the electrical feeder housing.
8. A circuit analyzer has been provided to you by MFT. Before connecting the surge protector or power cord, verify the integrity of your electrical source by plugging in the circuit analyzer. If the analyzer indicates the outlet is wired correctly, remove the analyzer and plug in the feeder. Plug the three-prong standard power cord into the J5-Power Entry connector located on the back of the electrical feeder housing and turn on the feeder. Please note that the power up sequence takes 30-60 seconds.

4 IP Feeder Main Parts

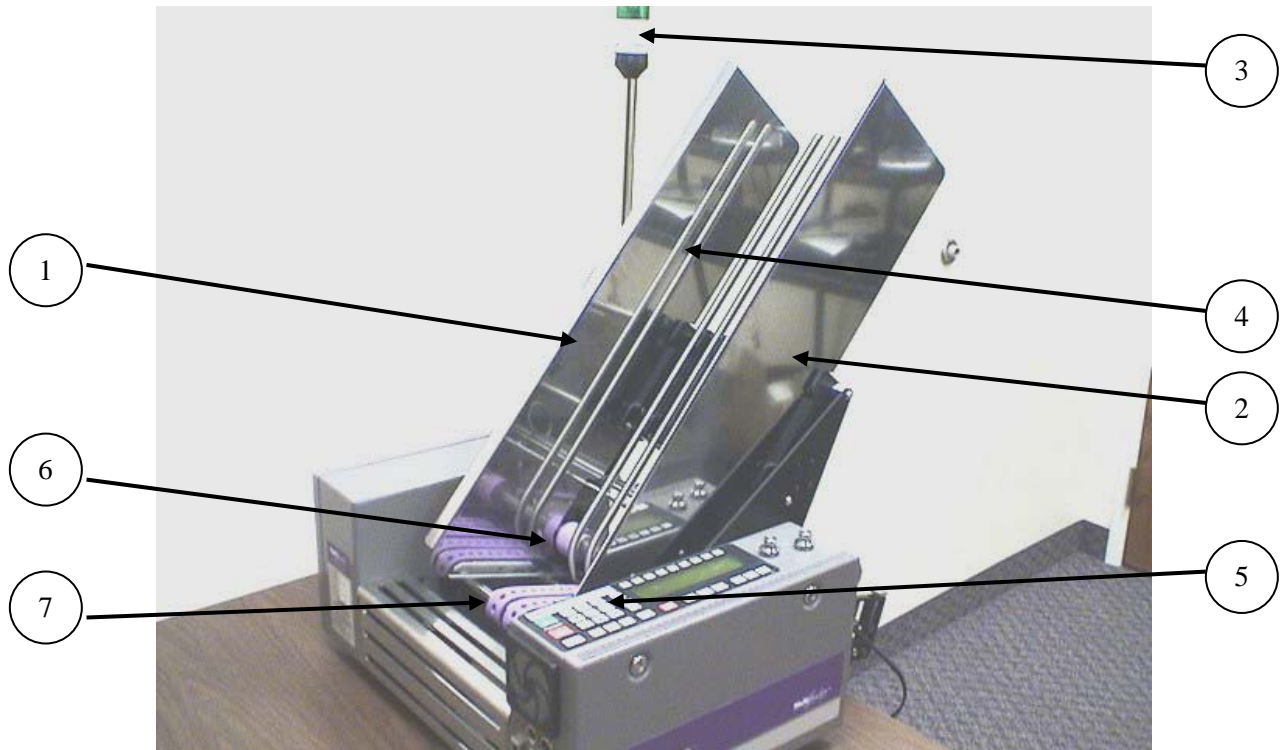

Figure 4.1 – IP Feeder Back View

Table 4.1 – IP Feeder Back View

Item	Part Number	Description
1 & 2	See Table 4.6	Product Side Plates Various Sizes Listed as Right & Left (Also available in sets)
3	80056-00	Signal Light Three Color
3	80054-00	Signal Light Three Color with Alarm
3	68261-00	5W Replacement Bulb
4	40135-00	Product Support Rod 12 27
5	53110-0D	Membrane Keypad MFT
6	See Table 4.2	Stripper Wheels
7	See Table 4.3	Feed Belts

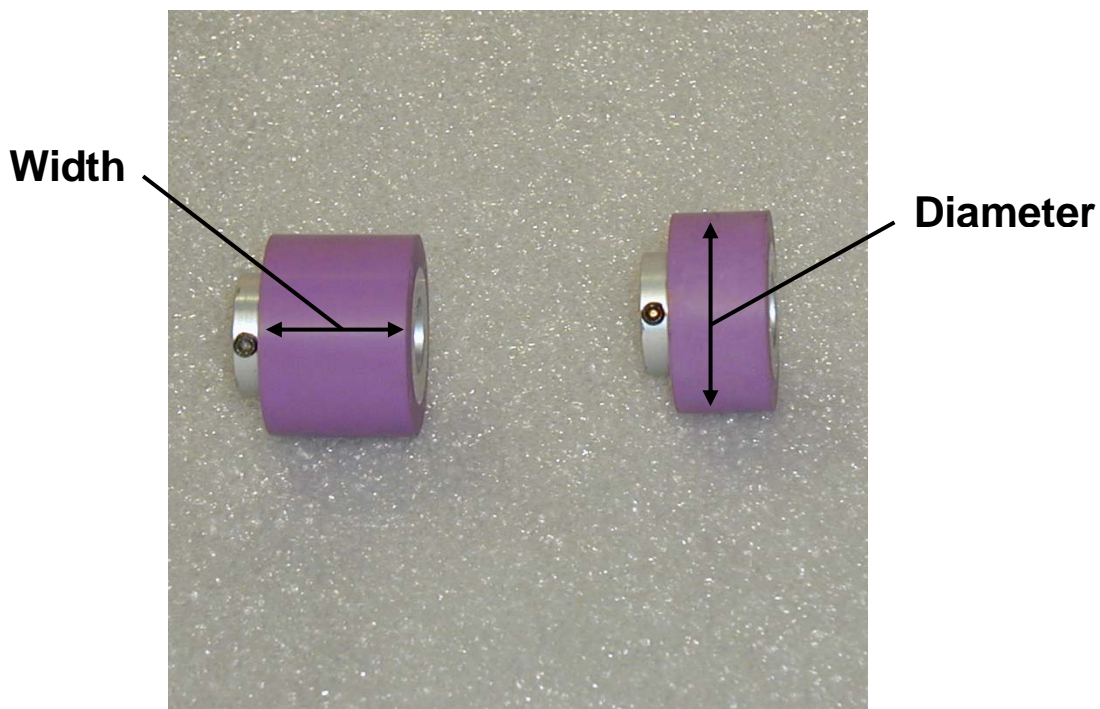

Figure 4.2 - IP Feeder Stripper Wheels

Table 4.2 - IP Feeder Stripper Wheels

Part Number	Description *
41254-00	Stripper Wheel 2046
41256-00	Stripper Wheel 3046
35214-01	M5X6 Set Screw with Brass Tip

*** First 2 digits indicate width, second 2 digits indicate diameter.**

Table 4.3 - IP Feeder Belts

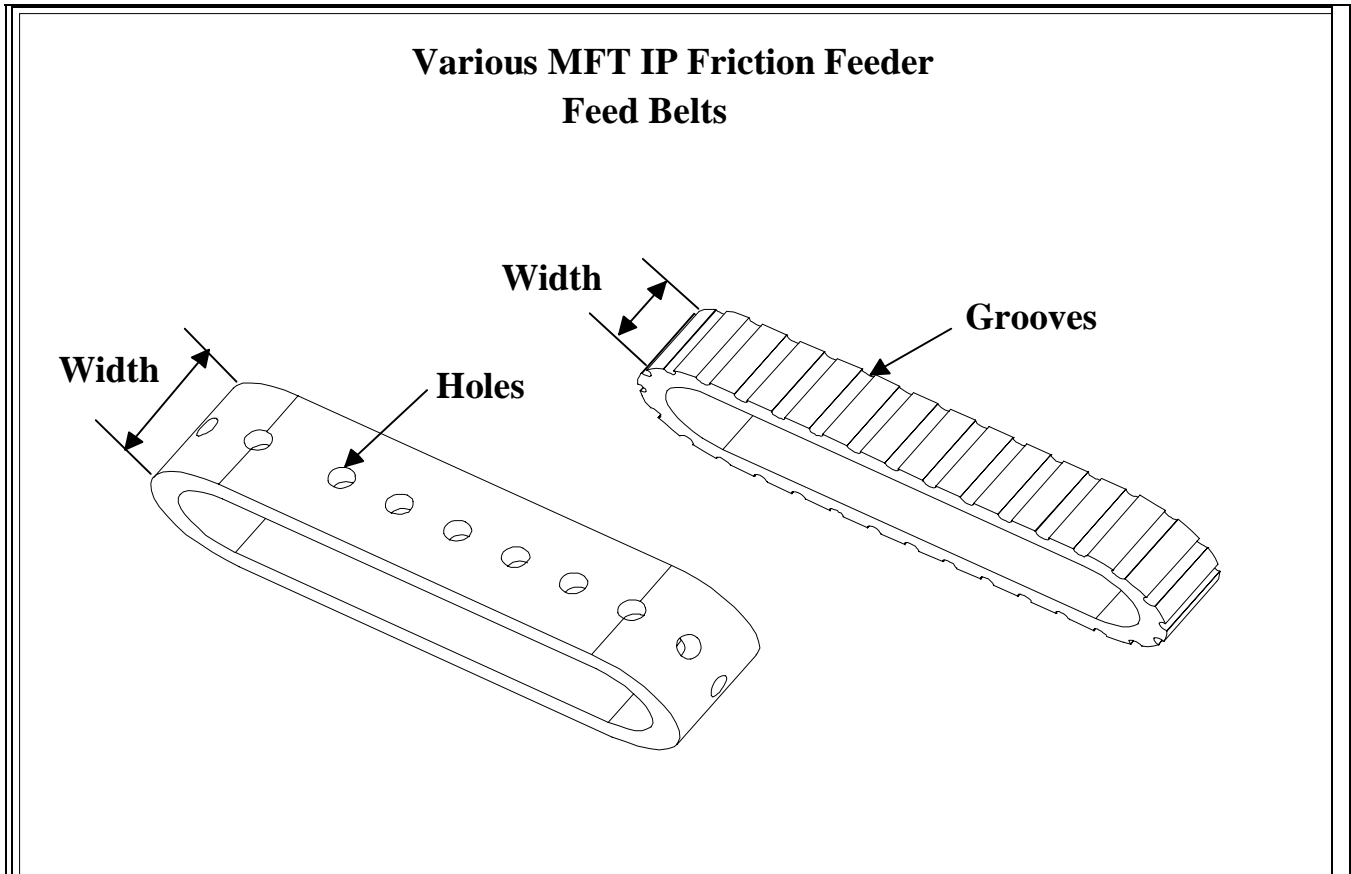

Width	Grooves	Holes	Part No.	Description
10 mm [0.394"]	No	No	11911-0A	Feed Belt ECG104606S
20 mm [0.787"]	No	No	11912-0A	Feed Belt ECG204606S
30 mm [1.181"]	No	No	11913-0A	Feed Belt ECG304606S
10 mm [0.394"]	Yes	No	11921-0A	Feed Belt ECG104606R
20 mm [0.787"]	Yes	No	11922-0A	Feed Belt ECG204606R
30 mm [1.181"]	Yes	No	11923-0A	Feed Belt ECG304606R
20 mm [0.787"]	No	Yes	11932-0A	Feed Belt ECG204606SV
30 mm [1.181"]	No	Yes	11933-0A	Feed Belt ECG304606SV

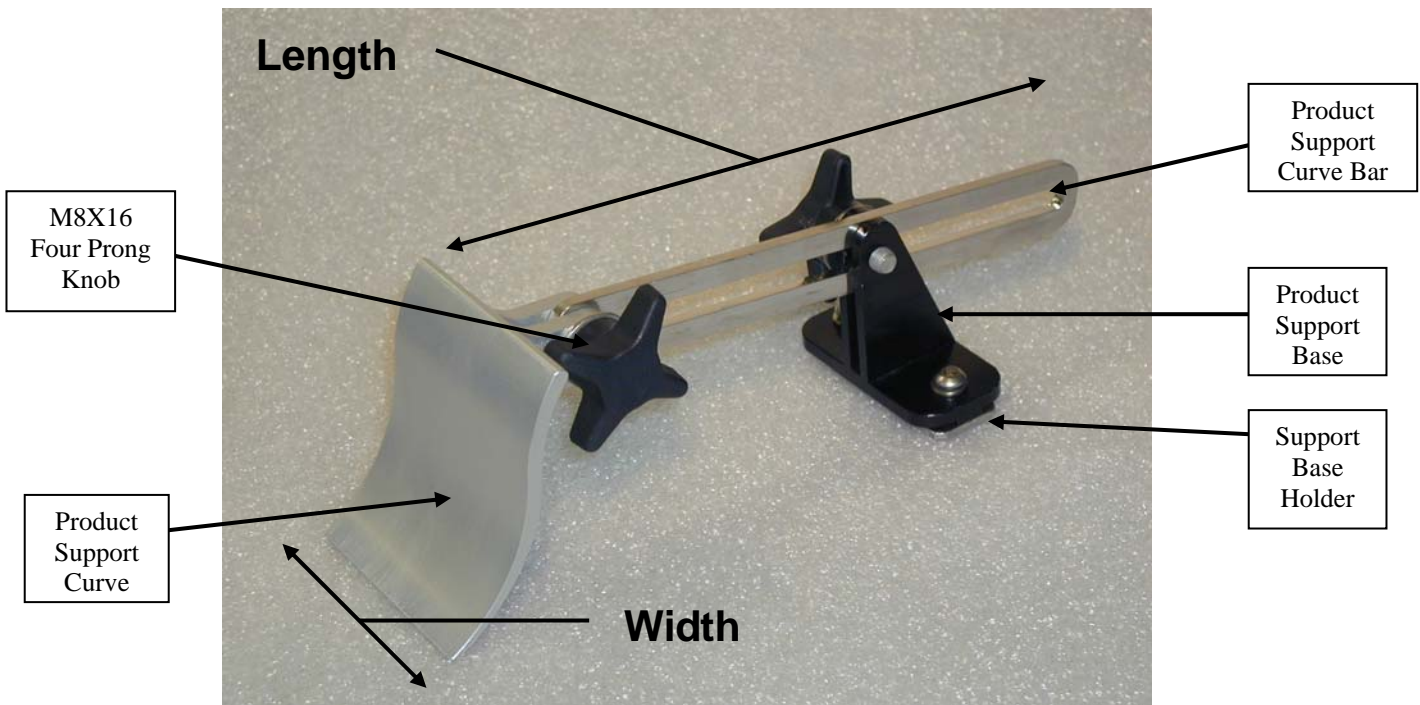

Figure 4.4 - IP Feeder Support Curve Assembly

Table 4.4 - IP Feeder Support Curve Assemblies/Accessories

Part Number	Description *
42000-00	Feeder Support Curve Assembly 50 x 80
42001-00	Feeder Support Curve Assembly 25 x 80
42002-00	Feeder Support Curve Assembly 25 x 140
42003-00	Feeder Support Curve Assembly 25 x 200
42004-00	Feeder Support Curve Assembly 50 x 140
42005-00	Feeder Support Curve Assembly 50 x 200
42006-00	Feeder Support Curve Assembly 75 x 80
42007-00	Feeder Support Curve Assembly 75 x 140
42008-00	Feeder Support Curve Assembly 75 x 200
20231-00	Product Support Curve 15mm
20213-00	Product Support Curve 25mm
20214-00	Product Support Curve 50mm
20219-00	Product Support Curve 75mm
20232-00	Product Support Curve 100mm
20215-00	Product Support Bar 80mm
20216-0A	Product Support Bar 140mm
20217-00	Product Support Bar 200mm
20218-0A	Product Support Base
20220-0B	Support Base Holder
30060-00	M8X16 Four Prong Knob

*** First Number indicates support curve width, second number indicates support bar length.**

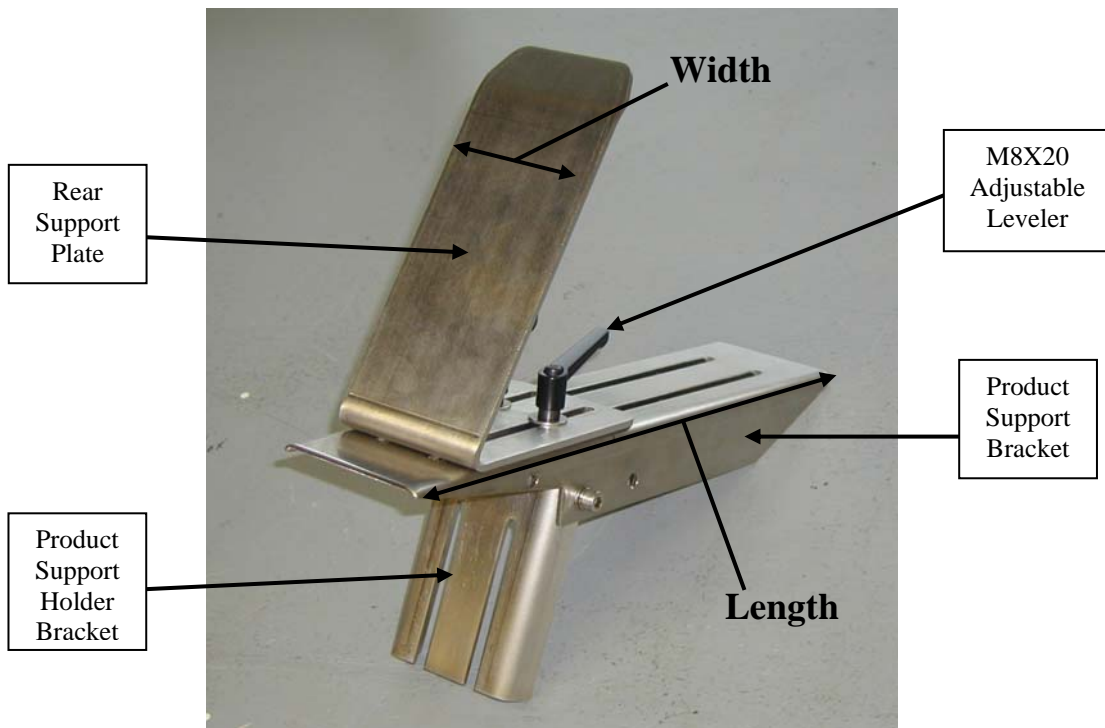

Figure 4.5 – IP Feeder Heavy Duty Support Curve Assembly

Table 4.5 – IP Feeder Heavy Duty Support Curve Assemblies

Part Number	Description *
41910-00	Product Support HD 100 425
41916-00	Product Support HD 100 625
41919-00	Product Support HD 100 825
41922-00	Product Support HD 100 1100
25203-0B	Support Bracket HD 100 425
25207-00	Support Bracket HD 100 625
25209-0B	Support Bracket HD 100 825
25211-00	Support Bracket HD 100 1100
25205-0A	Product Support Holder Bracket
20283-0A	Rear Support Plate 100 200
30063-00	M8X20 Adjustable Leveler

*** First number indicates rear support plate width, second number indicates product support bracket length.**

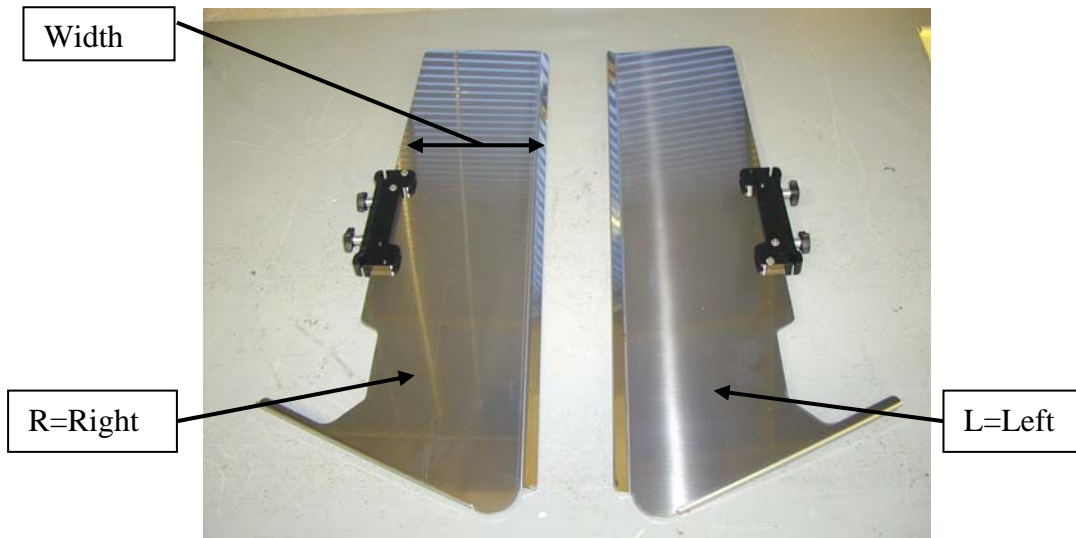

Figure 4.6 – IP Feeder Magazine Plates

Table 4.6 – IP Feeder Magazine Plates

Part Number	Description *	Set Part Number
42407-00	Product Side Plate Assembly 75 R	42409-00
42408-00	Product Side Plate Assembly 75 L	
42410-00	Product Side Plate Assembly 100 R	42412-00
4241100	Product Side Plate Assembly 100 L	
42413-00	Product Side Plate Assembly 125 R	42415-00
42414-00	Product Side Plate Assembly 125 L	
42416-00	Product Side Plate Assembly 150 R	42418-00
42417-00	Product Side Plate Assembly 150 L	
42419-00	Product Side Plate Assembly 175 R	42421-00
42420-00	Product Side Plate Assembly 175 L	
42422-00	Product Side Plate Assembly 200 R	42424-00
42423-00	Product Side Plate Assembly 200 L	
42425-00	Product Side Plate Assembly 225 R	42427-00
42426-00	Product Side Plate Assembly 225 L	
42428-00	Product Side Plate Assembly 250 R	42430-00
42429-00	Product Side Plate Assembly 250 L	

*** Number after the description indicates the plate width**

5 IP Feeder Discharge

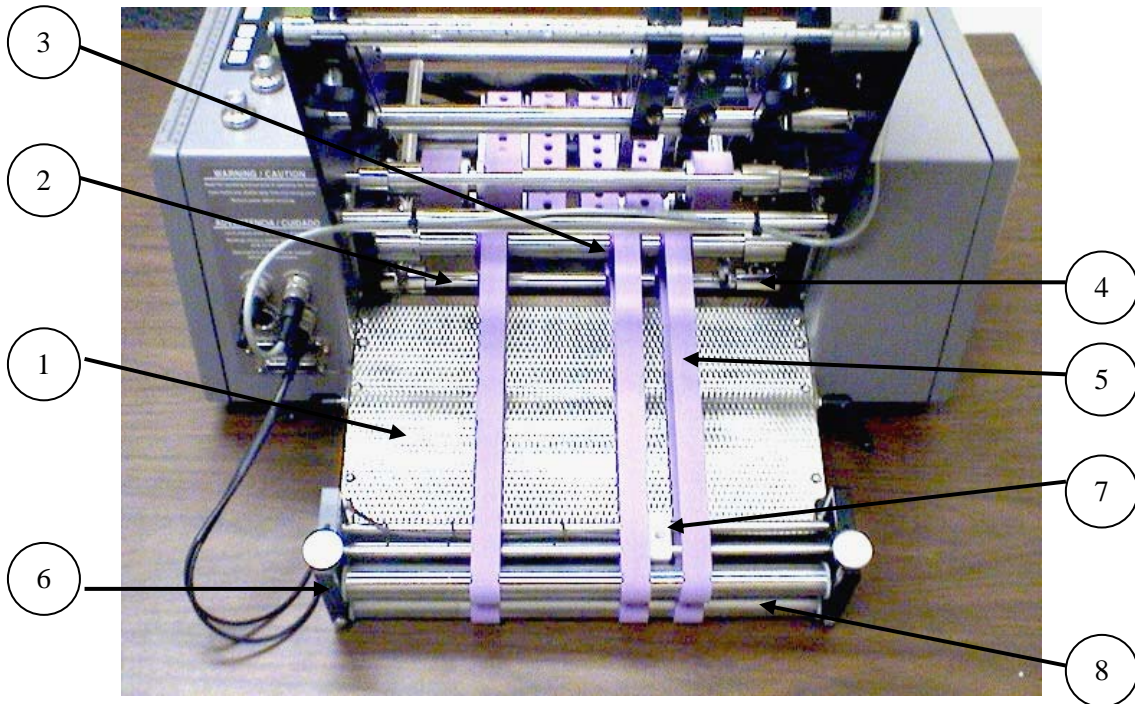

Figure 5.1 – IP Feeder Discharge

Table 5.1 – IP Feeder Discharge

Item	Part Number	Description
1	See Table 5.6	Discharge Tables
2	See Table 5.5	Center Piece Shafts
3	41282-00	Discharge Pulley 204620K
4	13555-01	Split Collar 20
5	See Table 5.4	Discharge Belts
6	See Table 5.2	Upper Exit Roller Assemblies
7	See Table 5.3	Product Sensor Pairs
8	See Table 5.2	Discharge Exit Roller Assemblies

Table 5.2 – IP Feeder Discharge Exit Roller Assemblies

Item	Part Number	Description
6	40273-00	Upper Exit Roller 350 20
6	40275-00	Upper Exit Roller 550 20
8	40263-00	Discharge Exit Roller 350 20
8	40265-00	Discharge Exit Roller 550 20

***Upper Exit Roller includes height adjustment assembly, Discharge Exit Roller consists of the roller assembly only.**

Table 5.3 – IP Feeder Product Sensor Pairs

Part Number	Description	Discharge Length
70072-00	Product Sensor Pair SD IP	180 mm
70074-00	Product Sensor Pair ED IP	275 mm
70076-00	Product Sensor Pair XED IP	450 mm
70077-00	Product Sensor Pair XLD IP	675 mm
70078-00	Product Sensor Pair SLD IP	975 mm

Table 5.4 – IP Feeder Discharge Belts

Width (mm)	Part Number	Description	Discharge Length
20	11772-01	SD Discharge Belt EPDM 204604	180 mm
20	11773-01	ED Discharge Belt EPDM 204604	275 mm
20	11774-01	XED Discharge Belt EPDM 204604	450 mm
20	11775-01	XLD Discharge Belt EPDM 204604	675 mm
20	11776-01	SLD Discharge Belt EPDM 204604	975 mm

Table 5.5 – IP Feeder Center Piece Shafts

Part Number	Description*
12637-02	Center Piece Shaft 350 20
12657-02	Center Piece Shaft 550 20

* First number indicates shaft length

Table 5.6 – IP Feeder Discharge Tables

Part Number	Description	Discharge Tables
22153-01	Discharge Table 350 SD	180 mm
22155-01	Discharge Table 550 SD	180 mm
22163-02	Discharge Table 350 ED	275 mm
22165-02	Discharge Table 550 ED	275 mm
22173-02	Discharge Table 350 XED	450 mm
22175-03	Discharge Table 550 XED	450 mm
22183-01	Discharge Table 350 XLD	675 mm
22185-01	Discharge Table 550 XLD	675 mm
22193-01	Discharge Table 350 SLD	975 mm
22195-01	Discharge Table 550 SLD	975 mm

6 IP Feeder Drive Section

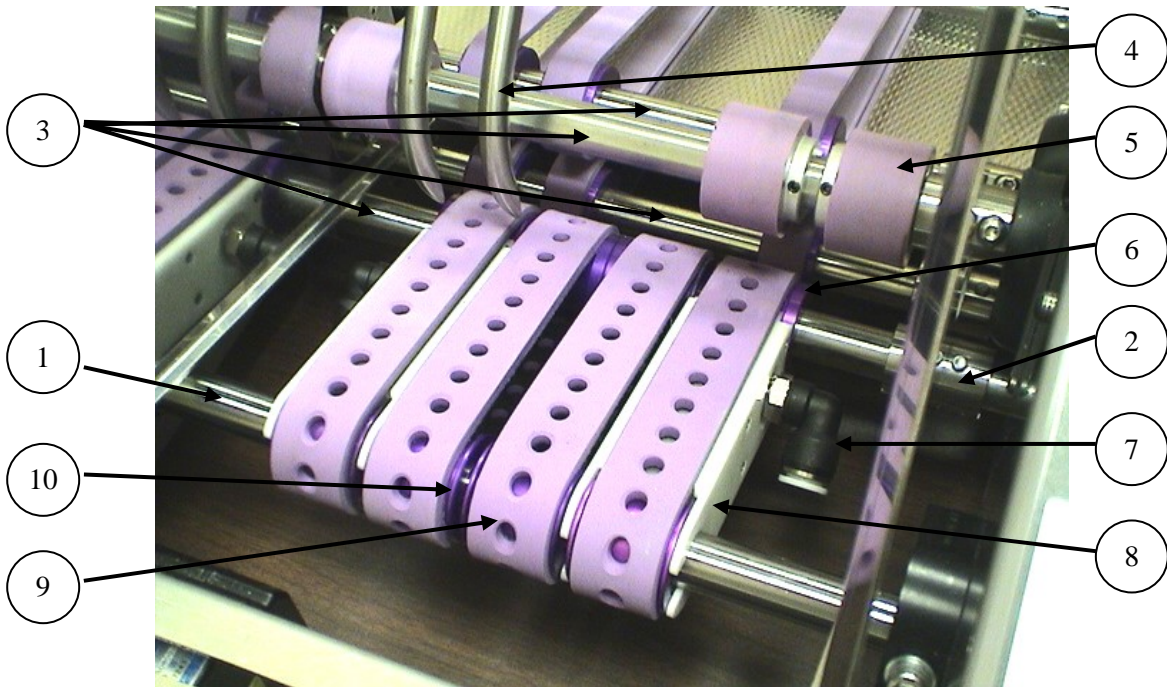

Figure 6.1 – IP Feeder Drive Section

Table 6.1 – IP Feeder Drive Section

Item	Part Number	Description
1	See Table 6.2	Spanning Shafts
2	13555-01	Split Collar 20
3	See Table 5.5	Center Piece Shafts
4	40135-00	Product Support Rod 12 27
5	See Table 4.2	Stripper Wheels
6	See Table 6.3	Drive Pulleys
7	28067-00	Fitting Elbow 500 Tube 375 NPT
8	42887-00	Vacuum Track Assembly 204606 20mm Wide
8	42888-00	Vacuum Track Assembly 304606 30mm Wide
9	See Table 4.3	Feed Belts
10	See Table 6.4	Idler Pulleys

Table 6.2 – IP Feeder Spanning Shafts

Part Number	Description
12337-01	Spanning Shaft 350 20
12357-01	Spanning Shaft 550 20

Table 6.3 – IP Feeder Drive Pulleys

Part Number	Description
41262-00	Drive Pulley 204620 20mm Wide
41263-00	Drive Pulley 304620 30mm Wide
35215-01	M5X8 Set Screw with Brass Tip

Table 6.4 – IP Feeder Idler Pulleys

Part Number	Description
41265-00	Idler Pulley 204620 20 mm Wide
41266-00	Idler Pulley 304620 30 mm Wide

7 IP Feeder Left Side Housing

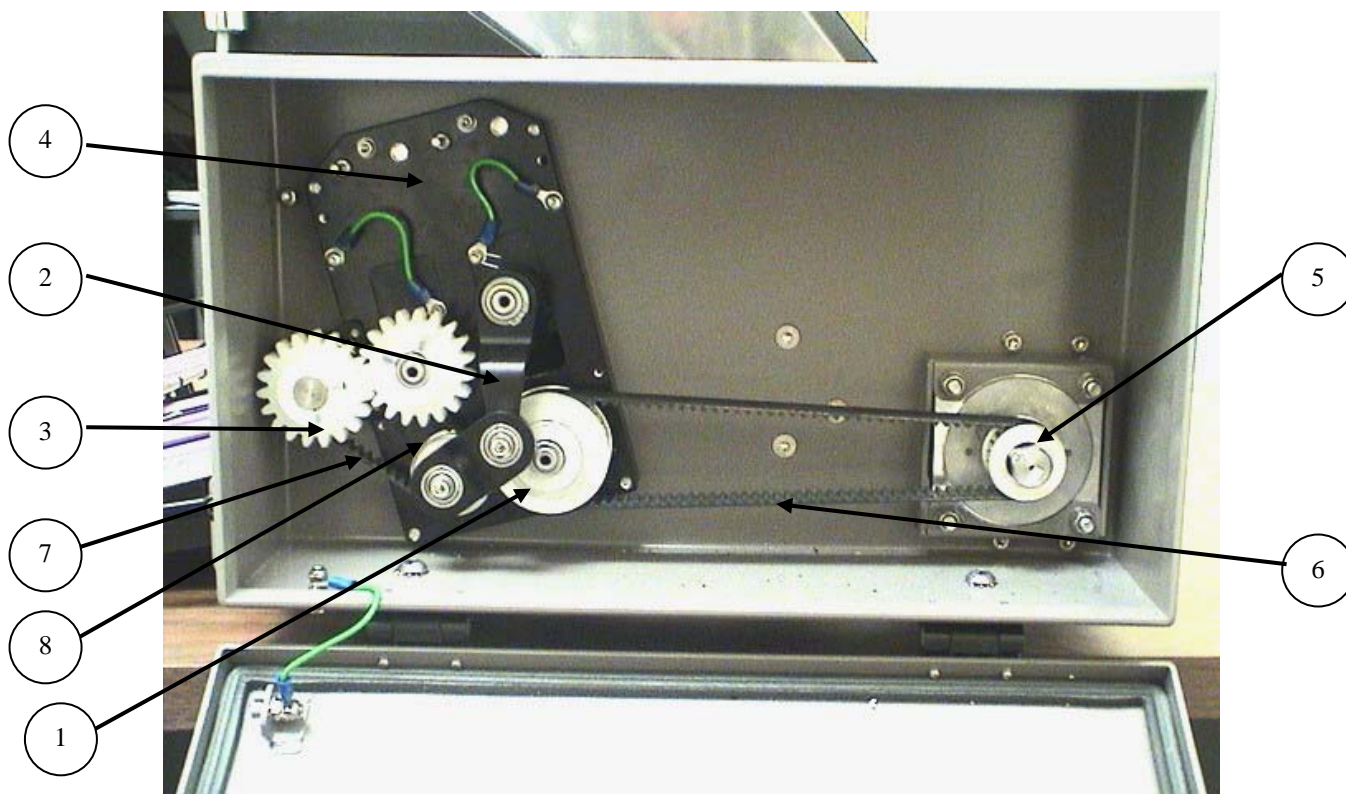

Figure 7.1 – IP Feeder Left Side Housing

Table 7.1 – IP Feeder Left Side Housing

Item	Part Number	Description
1	41378-00	Timing Belt Pulley 051532 16
2	41074-00	Stripping Crank Left
3	41291-00	Spur Gear 16 475 525
4	41046-00	Bearing Assembly MFT L
5	10529-0A	Timing Pulley 052815 25
6	11597-00	Timing Belt 0515117
7	11551-00	Timing Belt 050951
8	41364-00	Timing Belt Pulley 050922 16

8 IP Feeder Right Side Housing

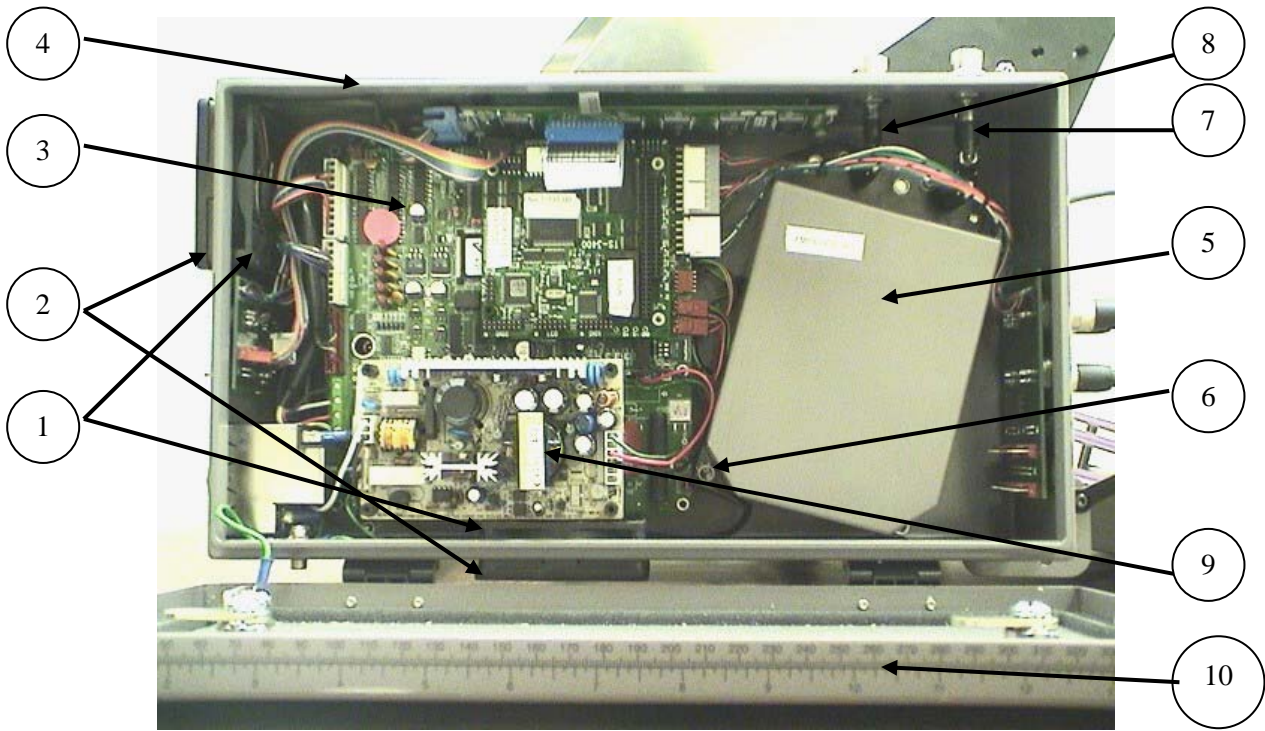

Figure 8.1 – IP Feeder Right Side Housing

Table 8.1 – IP Feeder Right Side Housing

Item	Part Number	Description
1	70187-00	Fan Assembly 80X80X15 213 W
2	37568-00	Fan Filter 80X80
3	70510-01	Feeder Control PCB Assembly
4	53110-0D	Membrane Keypad
5	22734-01	Shield Drive Assembly Right
6	35005-02	M6 Keps Nut
7	35774-00	Universal Double Joint 404
8	35772-00	Universal Double Joint 304
9	55018-00	Pow Supply DC-DC Conv Sgl Out
10	43582-00	Housing Lid MFT

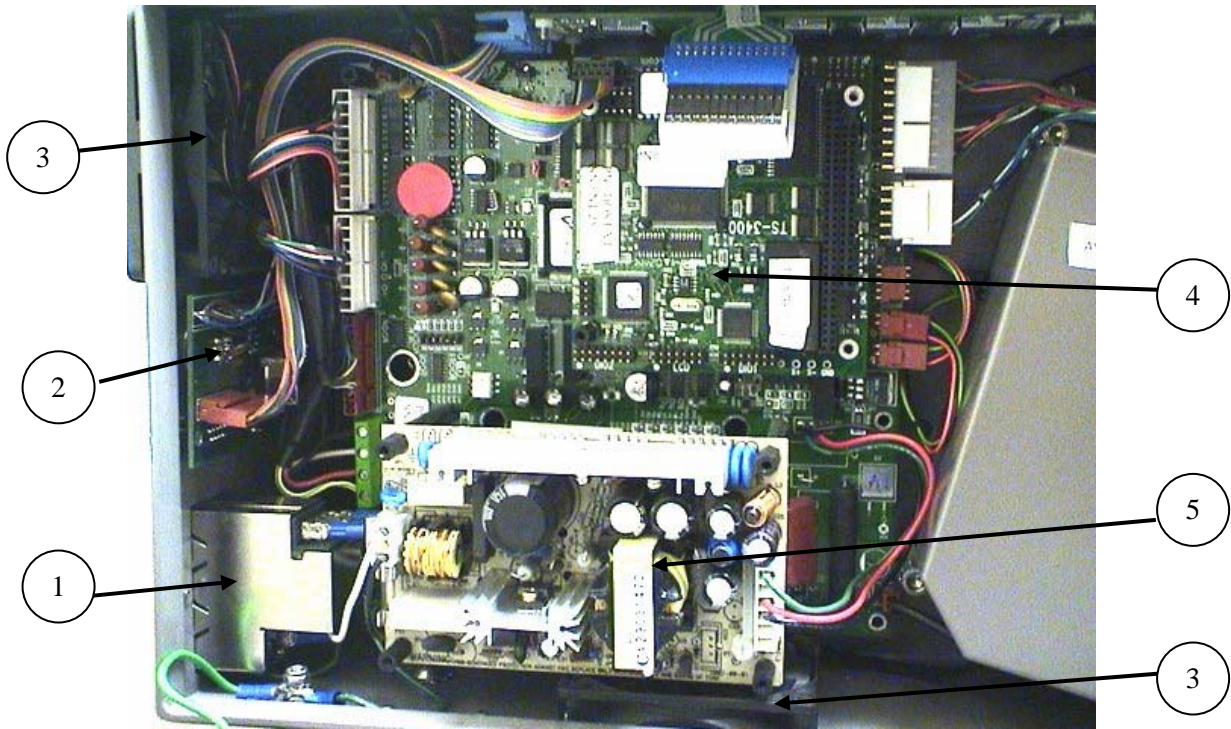

Figure 8.2 – IP Feeder Right Side Electronics

Table 8.2 – IP Feeder Right Side Electronics

Item	Part Number	Description
1	81610-00	Power Entry Module
2	70483-02	Connector PCB Feeder Rear
3	70187-00	Fan Assembly 80X80X15 213 W
4	70510-01	Feeder Control PCB Assembly
5	55018-00	Pow Supply DC-DC Conv Sgl Out

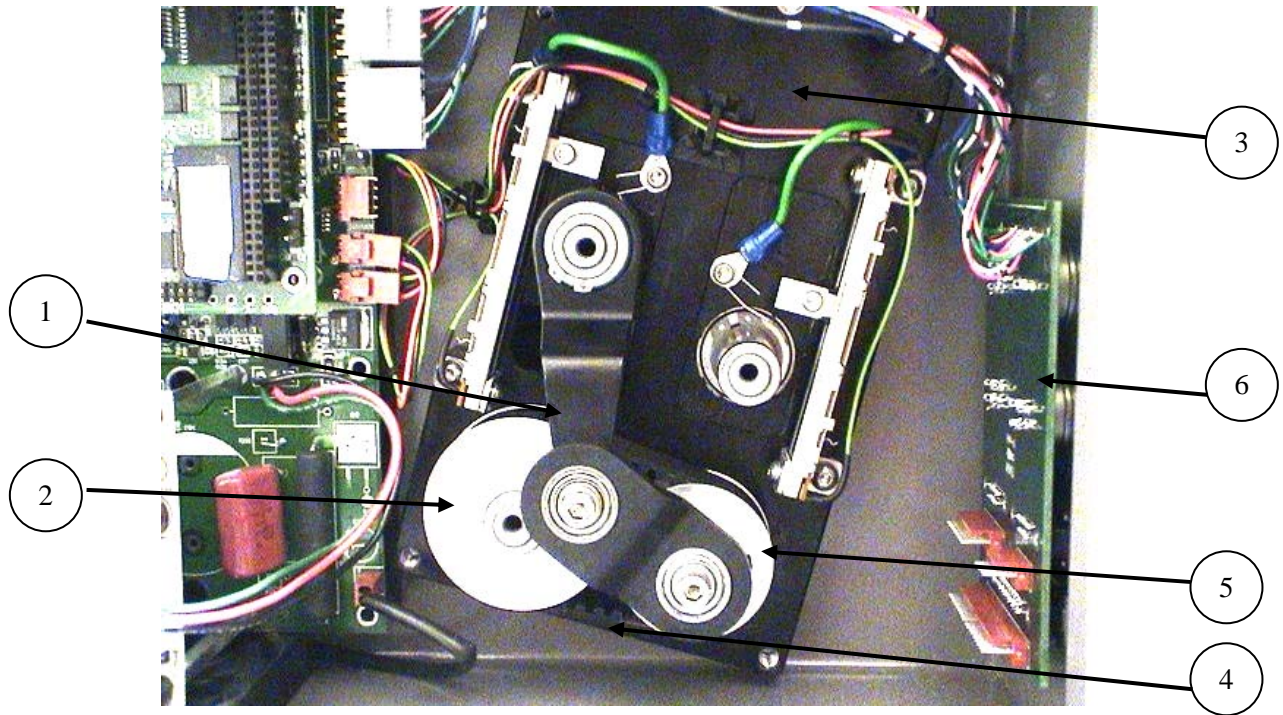

Figure 8.3 – IP Feeder Right Side Mechanical

Table 8.3 – IP Feeder Right Side Mechanical

Item	Part Number	Description
1	41072-00	Stripping Crank Right
2	41376-00	Timing Belt Pulley 051530 16
3	41047-00	Bearing Assembly MFT R
4	11546-00	Timing Belt 051546
5	41370-00	Timing Belt Pulley 051524 16
6	70485-02	Connector PCB Feeder Front

9 IP Feeder Sensors & Sensor Brackets.



Figure 9.1 – IP Feeder Start Sensors

Table 9.1 – IP Feeder Start Sensors

Item	Part Number	Description
Not Pictured	70095-00	Right Angle Optic Start Sensor
1	70100-00	Photo Optic Start Sensor
Not Pictured	70101-00	Start Sensor
Not Pictured	70102-00	Photo Optic Start Sensor Catch Tray
2	70103-00	Start Sensor ADJ
3	70104-00	Start Sensor Inductive Proximity
4	70105-00	Inductive Start Sensor
Not Pictured	70106-00	Start Sensor Retroreflective
Not Pictured	70108-00	Start Sensor Color Contrast
Note: All Start Sensors Have A 14 Pin Male Amphenol Connector		
Note: All Start Sensors Are PNP		

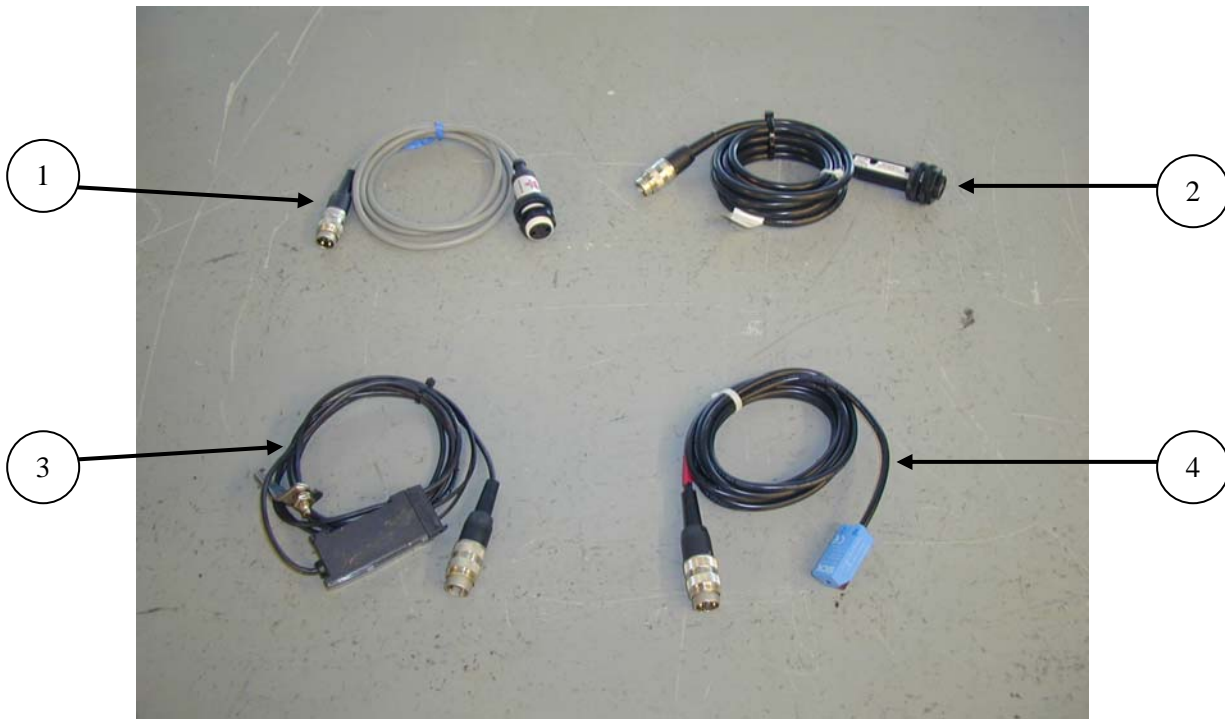

Figure 9.2 – IP Feeder Low Product Sensors

Table 9.2 – IP Feeder Low Product Sensors

Item	Part Number	Description
1	70089-00	Low Product Sensor 4' (4" Range)
Not Pictured	70090-00	Low Product Sensor 6' (4" Range)
2	70091-00	Low Product Sensor (2" Range)
3	70092-00	Fiber Optic Low Product Sensor (Adjustable)
Not Pictured	70093-00	Low Product Sensor
Not Pictured	70094-00	Low Product Sensor 24" (Adjustable)
4	70096-00	Low Product Sensor
Note: All Low Product Sensors Have A 3 Pin Male Amphenol Connector		
Note: All Low Product Sensors Are PNP		

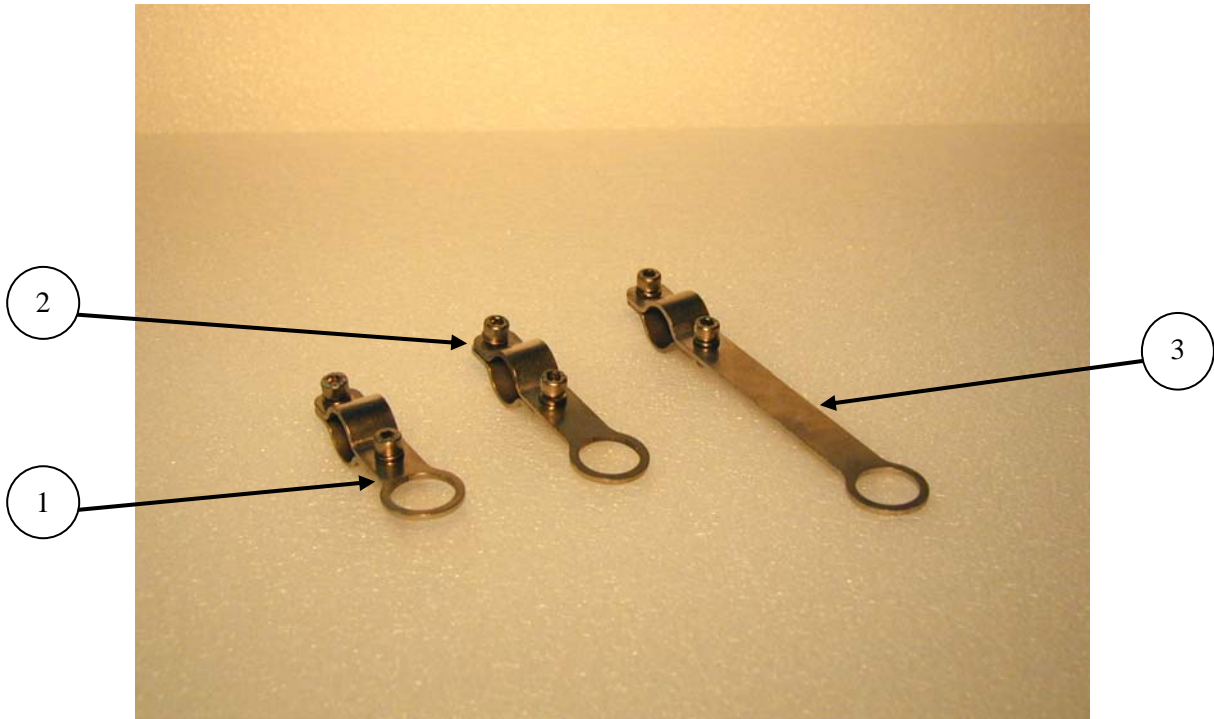

Figure 9.3 – IP Feeder Sensor Brackets

Table 9.3 – IP Feeder Sensor Brackets

Item	Part Number	Description
Not Pictured	41604-00	Product Sensor Bracket Assy 65mm Length
1	41605-00	Product Sensor Bracket Assy 75mm Length
2	41606-00	Product Sensor Bracket Assy 85mm Length
3	41607-00	Product Sensor Bracket Assy 145mm Length

10 IP Feeder Pressure Roller Assemblies



Figure 10.1 – IP Feeder Pressure Roller Assembly

Table 10.1 – IP Feeder Pressure Roller Assembly

Item	Part Number	Description
1	45734-00	Pressure Roller 350 N
1	45754-00	Pressure Roller 550 N
2	10452-00	O-Ring 328 70D N (Fits 1.9” Roller)
3	10454-00	O-Ring 330 70D N (Fits 2 3/8” Roller)

11 IP Feeder Static Bar Assemblies

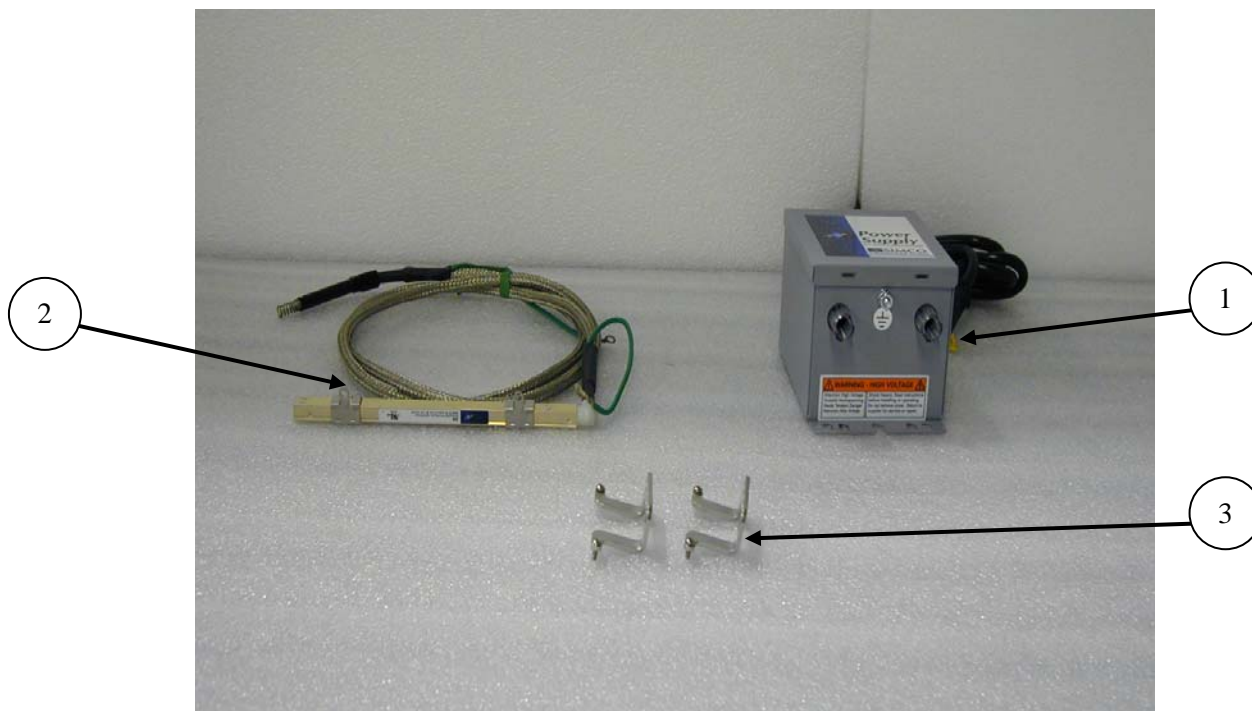

Figure 11.1 – IP Feeder Static Bar Assemblies

Table 11.1 – IP Feeder Static Bar Assemblies

Item	Part Number	Description
1	54180-00	Static Bar SM Power Supply
2	54200-00	SM Shockless Bar 200MM 90
2	54203-00	SM Shockless Bar 300MM 90
2	54206-00	SM Shockless Bar 400MM 90
2	54209-00	SM Shockless Bar 500MM 90
3	20710-00	Static Bar Bracket

12 IP Feeder Interfacing Equipment



Figure 12.1 – IP Feeder Interface Boxes

Table 12.1 – IP Feeder Interface Boxes

Item	Part Number	Description
1	70680-00	Start Signal Delay Box
2	70660-0B	Relay Interface Box



Figure 12.2 – IP Feeder Signal Interface Cable

Table 12.2 – IP Feeder Signal Interface Cable

Part Number	Description
70700-0A	Signal Interface Cable 10 FT
70702-0A	Signal Interface Cable 20 FT
70703-0A	Signal Interface Cable 30 FT
70704-0A	Signal Interface Cable 40 FT
71200-0B	ADT Interface Cable
50342-00	14 Pin Circular Connector Plug

13 IP Feeder Spare Part Kits

Table 13.1 – IP Feeder Accessory Kit P/N 92911-00

Part #	Part Description	Qty
39010-00	Setup Instructions	1
39500-00	Metric Ball End Hex Key Set	1
49001-01	Feeder/Stand Mount Bolt Kit	1
31412-00	Bolt M8X12 SHCS	4
35037-00	M8 Space Washer	4
35027-00	M8 Helical Spring Lock Washer	4
49003-00	Set Screw and Retaining Ring Kit	1
35215-01	M5X8 Set Screw with Brass Tip	1
35214-01	M5X6 Set Screw with Brass Tip	1
35416-00	M16 Retaining Ring External	2
49004-02	Magazine Bolt Kit	1
33216-00	Bolt M5X16 BHSS	2
35024-00	M5 Helical Spring Lock Washer	2
33316-00	Bolt M6X16 BHSS	2
35025-00	M6 Helical Spring Lock Washer	2
49005-02	Support Rod Bolt Kit	1
33216-00	Bolt M5X16 BHSS	2
35024-00	M5 Helical Spring Lock Washer	2
33316-00	Bolt M6X16 BHSS	2
35025-00	M6 Helical Spring Lock Washer	2
49006-00	Support Curve Bolt Kit	1
33316-00	Bolt M6X16 BHSS	2
35025-00	M6 Helical Spring Lock Washer	2
31420-01	Bolt M8X1.0X20 SHCS	2
35037-00	M8 Space Washer	2
49007-00	Power Entry Fuse Kit	1
63920-00	Power Entry Fuse 10A 5X20mm	1
53035-00	Power Cord	1
68011-00	Circuit Analyzer	1
39025-00	Setup, Maintenance, and Operating CD	1

Table 13.2 – IP Feeder Spare Parts Kit P/N 92905-00

Kit	Part #	Part Description	Qty	Use	
Hardware	31216-00	Bolt M5X16 SHCS	2	Stripping Crank	
	31316-00	Bolt M6X16 SHCS	2	Support Curve Mount	
	31330-00	Bolt M6X30 SHCS	8	Center Piece Shaft	
	31412-00	Bolt M8X12 SHCS	4	Feeder Mount Feet	
	31416-00	Bolt M8X16 SHCS	2	HD Support Curve Mount	
	31435-00	Bolt M8X35 SHCS	2	Spanning Shaft	
	32220-00	Bolt M5X20 FHSS	8	Support Rods, Side Plates	
	33112-00	Bolt M4X12 BHSS	6	Discharge Table	
	33116-00	Bolt M4X16 BHSS	6	Discharge Table Rods	
	33216-00	Bolt M5X16 BHSS	4	Upper Discharge Exit Roller Assembly	
	33316-00	Bolt M6X16 BHSS	4	Support Rods, Side Plates	
	33325-00	Bolt M6X25 BHSS	8	Center Piece Shaft	
	35034-00	M5 Space Washer	2	Stripping Crank	
	35037-00	M8 Space Washer	4	Feeder Mount Feet	
	35023-00	M4 Helical Spring Lock Washer	6	Discharge Table Rods	
	35024-00	M5 Helical Spring Lock Washer	2	Stripping Crank	
	35025-00	M6 Helical Spring Lock Washer	12	Support Rods, Side Plates, Center Piece Shaft	
	35027-00	M8 Helical Spring Lock Washer	6	Feeder Mount Feet, HD Support Curve Mount	
	35023-01	M4 Toothed Lock Washer	6	Discharge Table	
	35024-01	M5 Toothed Lock Washer	4	Upper Discharge Exit Roller Assembly	
	35027-01	M8 Toothed Lock Washer	2	Spanning Shaft	
	35042-03	Plastic Space Washer 640	2	Stripping Crank	
	35215-01	M5X8 Set Screw with Brass Tip	8	Drive and Discharge Pulleys, Stripper Wheels	
	35416-00	M16 Retaining Ring External	2	Stripping Crank	
	30020-00	M6X12 Adjustable Leveler	2	Discharge Assembly	
	30056-00	M6X16 Star Knob	4	Side Plates	
	Electrical	63920-00	Power Entry Fuse 10A 5X20mm	1	Power Entry Module
		68262-00	24 V 5W 45mm Bulb	1	Signal Light
Table 5.3		Product Sensor Pair (Specify Discharge)	1		
53110-0D		Membrane Keypad	1		
70187-00		Fan Assembly 80x80x15 213W	1		
Mechanical	11546-00	Timing Belt 051546	1		
	11551-00	Timing Belt 050951	1		
	11597-00	Timing Belt 0515117	1		
	30292-02	Bellow Height Adjustment IP	2		
	37568-00	Fan Filter 80x80	2		
	41291-00	Spur Gear 16 475 525	1		
	Table 6.3	Drive Pulley (Specify Width)	1		
	Table 6.4	Idler Pulley (Specify Width)	1		